



OIL & GAS

MODEL 136 / 236 / 336 - AI/AF COMPACT, HIGH-ACCURACY DIFFERENTIAL PRESSURE TRANSMITTER



STANDARD WIRING

PIN OR WIRE COLOR	MODEL 136	MODEL 236	MODEL 336
A/1/RED	+EXC	+EXC	+EXC/SIG
B/2/GRN	+SIG	+SIG	N/C
C/3/WHT	-SIG	N/C	N/C
D/4/BLK	-EXC	-EXC/SIG	-EXC/SIG
E/5/BLU	N/C	N/C	PROGRAM GND*
F/6/ORG	N/C	PROGRAM*	PROGRAM*

* FOR FACTORY USE ONLY, DO NOT CONNECT

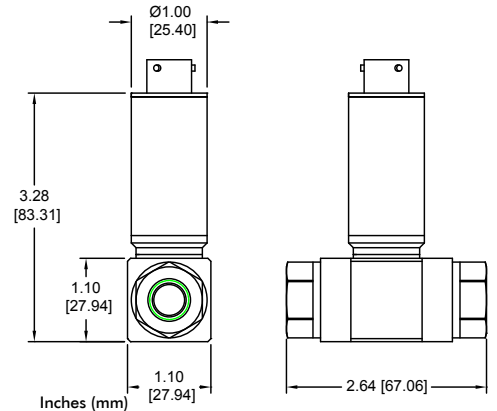

**REF DIMENSIONS ONLY.
CONSULT FACTORY FOR ACTUAL DIMENSIONS.**



PRODUCT OVERVIEW:

The Model 136/236/336-AI/AF from GP:50 is a family of highly accurate, digitally compensated differential pressure transducers. Model 136/236/336-AI/AF measures differential pressure ranges as low as 20" WCD and line pressures up to 1000 PSID (69 BAR) in a compact size. Customers may also choose from among multiple accuracy, digital output, process and electrical connections. Please consult the factory for details.

FEATURES:

- Compact design
- Up to $\pm 0.05\%$ FSO accuracy
- 1 PSID thru 500 PSID (0.1 thru 35 BAR D)
- Line pressure up to 1000 PSI (69 BAR)
- All-welded 316L stainless steel wetted parts
- High shock and vibration resistance
- Fast response time

APPLICATIONS:

- Liquefied natural gas (LNG) transport and storage
- Automotive test stands
- Aircraft engine test stands
- Flow measurements
- Filtration
- Tank level
- Leak testing

OPTIONS:

- Accuracy options to $\pm 0.05\%$ FSO
- Digital output options; CAN Bus, USB, RS-485 & RS-232
- Comprehensive selection of process and electrical connections

*For details of available approvals go to:
<https://www.gp50.com/certifications>



GP:50 MODEL 136 / 236 / 336 - AI/AF

REFERENCE SPECIFICATIONS

(Standard configurations shown, consult factory for other options)

ELECTRICAL	
Output Signal:	(Model 136) 3, 5, 10 mV/V (Model 236) 0 to 5 Vdc, 0 to 10 Vdc option (Model 336) 4-20 mA
Excitation Voltage:	(Model 136) 5.0 to 15 Vdc (Models 236, 336) 9.0 to 32 Vdc
Response Time:	<5 ms 10% to 90%

MATERIALS OF CONSTRUCTION	
Wetted Parts:	316L Stainless Steel
Housing:	300 Series Stainless Steel
Internal Fill:	Silicone Oil (Fomblin Oil Available)

ACCURACY (RSS): Hysteresis, Non-Linearity & Repeatability @ +70 °F	
Standard:	±0.25% FSO
Improved:	±0.10%, ±0.05% FSO
Zero & Span Balance:	±0.5% FSO (Optional Zero & Span Adjust)
Optional Variations:	Zero & span, shunt calibration, alternate connectors, pressure ports

MECHANICAL	
Process Connection:	1/4" NPT (F) (Consult factory for other options)
Electrical Connection:	336AI: 6-pin Amphenol PTIH-10-6P stainless steel or equivalent standard, options available 336AF: 1/2" NPT (M) conduit w/18" 18 AWG leads
Proof Pressure:	2X FSO
Burst Pressure:	5X FSO
Line Pressure:	1000 PSI (69 BAR)
Orientation Effect ≤2 PSI:	±3.5% FSO, Rotated 90° from Horizontal
Approximate Weight:	8 oz (254 gm)

PRESSURE RANGES	
1 PSID thru 500 PSID (0.1 thru 35 BAR D) (Other ranges available)	

THERMAL SPECIFICATIONS	
Operating Range:	-40 °F to +250 °F (-40 °C to + 121 °C)
Operating Process:	-40 °F to +250 °F (-40 °C to + 121 °C)
Compensated Range:	0 °F to +185 °F (-17.7 °C to +85 °C)
Storage Ambient:	-50 °F to +260 °F (-46 °C to +127 °C)
Effect on Zero/Span:	(Model 136): ±1.0% FSO/100 °F (Model 236/336): Standard: ±0.50% FSO/100 °F Improved: ±0.25% FSO/100 °F

APPROVALS:	
ATEX/IEC Intrinsically Safe: II 1 G Ex ia IIC T5 Ga	
ATEX/IEC Flameproof: II 2 G Ex b T4 to T6	

