



Pressure, Level & Temperature Transmitters & Transducers

INSTALLATION MANUAL

Models 114/214/314



TABLE OF CONTENTS

1. [Introduction](#)
 - 1.1 [Product Description](#)
 - 1.2 [Warning](#)
 - 1.3 [Unpacking/Inspection](#)
 - 1.4 [Using this Manual](#)
2. [Installation](#)
 - 2.1 [Mounting/Process Connection](#)
 - 2.2 [Power Supply](#)
 - 2.3 [Wiring/Grounding](#)
 - 2.4 [Environment](#)
3. [Operation & Maintenance](#)
4. [Troubleshooting & Return Information](#)
5. [Warranty](#)



Pressure, Level & Temperature Transmitters & Transducers

1. INTRODUCTION

1.1 Product Description

Model 114/214/314 is an Ultra High Differential Pressure Transducer with ranges from 500 PSID to 20,000 PSID in mV/V, VDC and mA outputs, consult the serialized calibration record provided with each individual unit.

1.2 Warning

Pressurized vessels and associated equipment are potentially dangerous. The product described in the guide should be operated only by personnel trained in the procedures that will assure safety to themselves, to others, to the equipment, and to the product. Specific warnings are noted as  in specific installation/operation sections.

1.3 Unpacking and Inspection

All models covered in this manual are carefully tested, inspected and packed. Upon receipt of the shipment thoroughly inspect the transducer. If you see any visible signs of obvious shipping damage, notify the freight company immediately.

1.4 Using this Manual

This manual is intended to help the end user install, maintain, and provide general service of GP:50 Model 114/214/314 Ultra High Differential Pressure Transducer. The user should have a general understanding of current loops & general instrument control. All aforementioned models are precision instruments and should be given the same care as any other precision instrument during installation and operation.

2. INSTALLATION

2.1 Mounting/Process Connection

Model 114/214/314 has ¼" NPT (F) process connections that can be mounted directly to the process ports and do not require mounting brackets. Installation of the device shall be in accordance with industry standard pipe fitting requirements for this size. During installation or removal, torque should only be applied at the wrench flats provided on the pressure port. As a rule, the device shall be "wrench-tight" to avoid leakage from the process connection.



Ensure media is compatible with 17-4 PH stainless steel (standard material, optional materials available) check part number to verify wetted material to avoid premature corrosion of the diaphragm. This can cause performance degradation and eventual sensor failure.



Properly tighten process connections before applying pressure to ensure no leaks or mechanical failure can occur.



Never insert sharp objects into diaphragm. This could cause permanent damage the sensor and/or mechanical failure/diaphragm rupture.



Pressure, Level & Temperature Transmitters & Transducers

2.2 Power Supply Connection

Consult power requirements listed on the Calibration Record provided with each serialized individual unit. For best operation the pressure transducer needs clean regulated power with output impedance less than 20Ω . As loads are added to the current loop (galvanic barriers, current measuring devices resistors), the minimum excitation voltage must increase in order to maintain proper operating voltage. Refer to datasheet for additional electrical specifications.

2.3 Wiring & Grounding

Consult wiring listed under Electrical Connections on the Calibration Record provided with each serialized individual unit. Do not run wires next to power lines, electrical systems, motors, generators, or any other equipment which may generate a significant amount of electrical noise or magnetic fields.

A 4-20 mA transmitter requires a DC power supply (typically 10-36 VDC) and mA meter wired in a current loop. Connect the Red wire of the transducer to the +Terminal of the power supply and the Black wire of the transducer to the +Input terminal of the meter. Connect the -Input terminal of the meter to the -Terminal of the power supply.

A VDC transducer requires a DC power supply (10-36 VDC) and voltmeter. Connect the Red wire from the transducer to + on the power supply, the Green wire to the +Signal of the VDC meter and the Black wire from the transducer to both the -Power on the power supply and -Signal on the VDC meter.

An mV/V transducer requires a regulated 5-15 VDC power supply and voltmeter. Connect the Red wire from the transducer to + on the power supply, the Green wire to the +Signal of the VDC meter, the Black wire from the transducer to the -Power on the power supply and White wire to -Signal on the VDC meter.

See the wiring guide below.

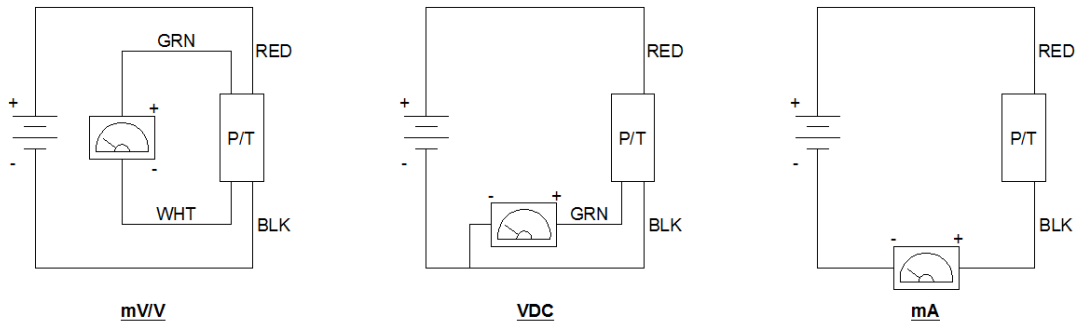



Pressure, Level & Temperature Transmitters & Transducers

2.4 Environment

The operating temperature range should be from -20 °F to 190 °F (-29 °C to 88 °C). Mount the unit as close to the process as possible with the ambient temperature surrounding the electronics falling within the operating range.



Protect electrical connection from direct/continued exposure to fluids. Moisture ingress can occur and cause eventual electrical failure.

3. OPERATION & MAINTENANCE

Model 114/214/314 is designed to produce respective output (3 mV/V, 0-5 VDC, 4-20mA) in direct proportion to the differential pressure. Specific pressure range, input voltage requirements and electrical connections are marked on unit. Appropriate mating connections are required for proper installation and safety. Other port and electrical connections are available and noted as option code in part number.



Install only after verifying both input power and line pressure are off and at zero.



Replace broken fasteners (available through the factory) as they may compromise the seal and cause contamination and/or electronics failure.



Observe safe ESD handling precautions to avoid static damage to sensitive components.



Pressure, Level & Temperature Transmitters & Transducers

4. TROUBLESHOOTING & RETURN INFORMATION

No output

- Verify power supply voltage meets transducer requirements
- Check wiring connections
- Verify pressure if being applied
- Verify output load is not shorted

Erratic output or zero drift

- Verify pressure applied is constant
- Verify power supply remains within specifications
- Inspect electrical connections for discontinuity or damage
- Verify output with a multi-meter
- Check insulation resistance between amplifier and transducer case

Slow Response

- Verify pressure port is not clogged

* If the problem persists, please call the factory as indicated below for assistance. Please have the following information ready:

- Serial number
- Model number
- Loop setup details (power supply, resistor, cable routing/length)
- Which action caused device failure

Contact: sales@gp50.com

Phone: (716) 773-9300



Repairs should only be done by GP:50. Repairs done by customer will void any warranties and may cause permanent damage to unit. Repairs done by customer on Intrinsically Safe units will void the approvals and are a potential explosion hazard.



Returned products that have been exposed to hazardous substances must be cleaned prior to return and include the Material Safety Data Sheet for all substances.



Pressure, Level & Temperature Transmitters & Transducers

5. WARRANTY

GP:50 warrants its products to the original customer/purchaser against defects in material and workmanship for a period of one (1) year from the date of delivery by GP:50, as shown in its shipping documents, subject to the following terms and conditions:

Without charge GP:50 will repair or replace products found to be defective in materials or workmanship within the warranty period provided that:

1. The product has not been subjected to abuse, neglect, accident, incorrect wiring (not provided by GP:50), improper installation or servicing, or use in violation of instructions furnished by GP:50.
2. As to any prior defect in materials or workmanship covered by this warranty, the product has not been repaired or altered by anyone except GP:50 or its authorized service agencies.
3. The serial number has not been removed, defaced or otherwise changed.
4. Examination discloses, in the judgment of GP:50, a defect in materials or workmanship which developed under normal installation, use and service.
5. GP:50 is notified in advance of, and approves, the return by issuing a Return Material Authorization Number; and the products are returned to GP:50 transportation prepaid. Products returned without an RMA number will not be accepted and will be returned to sender at sender's expense.

THIS WARRANTY IS THE ONLY WARRANTY AND IS IN LIEU OF ANY OTHER WARRANTY EXPRESSED OR IMPLIED, INCLUDING ANY WARRANTY OR MERCHANTABILITY OR FITNESS. NO REPRESENTATIVE OR PERSONS ARE AUTHORIZED TO GIVE ANY OTHER WARRANTY OR TO ASSUME FOR GP:50 ANY OTHER LIABILITY IN CONNECTION WITH THE SALE OF ITS PRODUCTS. GP:50 DOES NOT ASSUME THE COSTS OF REMOVAL AND/OR INSTALLATION OF THE PRODUCT OR ANY OTHER WORKMANSHIP, NOR WILL GP:50 BE LIABLE FOR ANY CONSEQUENTIAL DAMAGES RESULTING FROM THE USE OR INSALLATION OF ITS PRODUCT.

For a copy of our warranty policy and to fill out a warranty registration form, visit our website at: <https://www.gp50.com/products/warranty/>

For assistance with repairs, call our Repair Dept. at 716-773-9300, ext. 237, or complete a Repairs, Returns, RMA form at: <https://www.gp50.com/resources/repairs-returns-rma/>.

Copyright © 2008 GP:50 NY LTD. All rights reserved.

This specification must not be reproduced in any form without written permission of the copyright owner.