

## MODEL 7770 HIGH TEMPERATURE TRANSDUCER

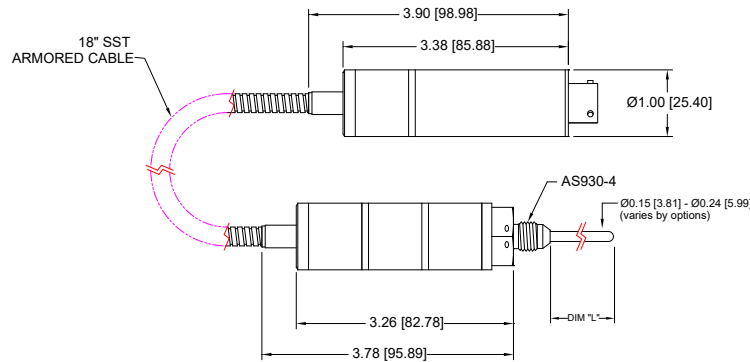

### STANDARD WIRING

PIN	VDC	4-20mA
A/1	+EXC	+EXC/SIG
B/2	+SIG	N/C
C/3	-SIG	N/C
D/4	-EXC	-EXC/SIG
E/5	N/C	N/C
F/6	N/C	N/C

L = 0.50 TO 7.00 INCH PROBE LENGTH

**REF DIMENSIONS ONLY.  
CONSULT FACTORY FOR ACTUAL DIMENSIONS.**

### PRODUCT OVERVIEW:

The Model 7770 Series from GP:50 is a family of extreme high-temperature transducers, offering consistent measurement accuracy in temperatures up to +500 °F (+260 °C). Their lightweight, all stainless steel construction incorporates on-board isolated electronics, which are remotely mounted via stainless steel armor jacketed flex tubing. The onboard electronics are designed to offer a high-level 4-20 mA, 0 to 5 Vdc, or 0 to 10 Vdc output. Direct transducer mounting can also provide greater process media measurement accuracy. The high-reliability of the Model 7770 Series has been field-proven over 25 years and hundreds of applications.

### FEATURES:

- Rated to +500 °F (+260 °C) process temperatures
- Standard designs rated to 2000 PSI (138 BAR), Special designs to 30,000 PSI (2,068 BAR)
- Remote electronics via stainless steel armored flex
- 4-20 mA output

### APPLICATIONS:

- High temperature gas measurement
- Propulsion Systems
- Military and Defense Applications

### OPTIONS:

- Custom probe lengths
- 0 to 5 Vdc, 0 to 10 Vdc output (4-wire isolated option)
- Digital Outputs - CanBUS, RS485, USB
- Remote electronic cable lengths to 36"
- Hydrogen or LOX compatibility options
- Various MIL-SPECS available. Consult factory.

# GP:50 MODEL 7770

## REFERENCE SPECIFICATIONS

(Standard configurations shown, consult factory for other options)

ELECTRICAL	
Output Signal:	0 to 5 Vdc or 0 to 10 Vdc (isolated options) 100 Ω 2-wire platinum RTD standard 1,000 Ω 2-wire platinum RTD optional (3 & 4 wire options)
Excitation Voltage:	10 to 36 Vdc (Options may affect this)
Response Time:	<2 sec

MATERIALS OF CONSTRUCTION	
Wetted Parts:	17-4 PH (Inconel, Monel or Nitronic 50 available) (Process pressure may affect material)
Housing:	316L Stainless Steel
O-Ring:	Buna-N (Nitrile) is standard. (Consult factory for other materials)
Flex Tubing:	18" Armored Tubing (24" & 36" Options)

ACCURACY (RSS): Hysteresis, Non-Linearity & Repeatability @ +70 °F	
Standard:	<±0.2% FSO
Improved:	±0.10% FSO
Zero/Span Balance:	±1% FSO Each

(BFSL method used. Improved options available.)

Calibration:	NIST Traceability Cert
Workmanship:	IPC-A-610 Soldering
Quality System:	AS9100

Options may affect specifications.  
Please consult factory for your specific needs.

MECHANICAL	
Process Connection:	AS930-4 pressure port
Electrical Connection:	MIL PTIH-10-6P standard, options available
Probe Length:	1.55" (custom lengths available)
Probe Pressure Rating:	2,000 PSI (Ranges to 30,000 PSI available)
Approximate Weight:	10 oz. (0.2 kg)

SYSTEM PRESSURE	
Up to 2000 PSI (138 BAR), Optional 10K PSI (689 BAR)	

TEMPERATURE RANGES	
+70°F to +500 °F (+21.1 °C to +260 °C)	

