

MODEL 7900 FLIGHT HERITAGE FLOW-THRU PRESSURE TRANSDUCER

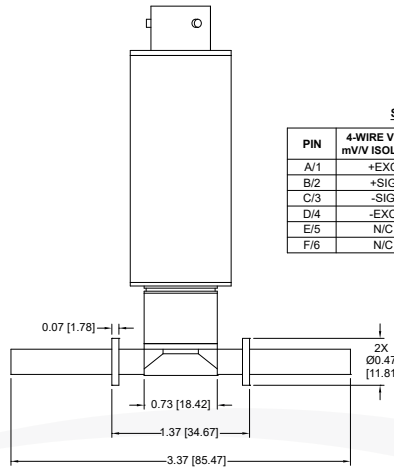

STANDARD WIRING

PIN	4-WIRE VDC & mV/V ISOLATED	4-WIRE VDC NON-ISOLATED	3-WIRE VDC
A/1	+EXC	+EXC	+EXC
B/2	+SIG	+SIG	+SIG
C/3	-SIG	-SIG*	N/C
D/4	-EXC	-EXC*	-EXC/SIG
E/5	N/C	N/C	N/C
F/6	N/C	N/C	N/C

*COMMONS JUMPERED

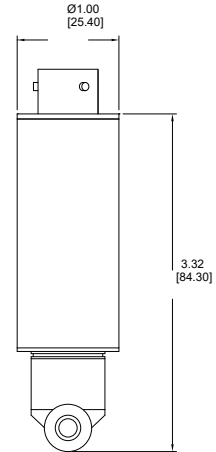

**REF DIMENSIONS ONLY.
CONSULT FACTORY FOR ACTUAL DIMENSIONS.**

PRODUCT OVERVIEW:

Model 7900 series is a light weight flow-thru pressure transmitter designed for flight propulsion systems. The flow thru design is engineered to measure up to 0.1% of full scale pressure flow across the sensor and will stand up to the rigorous conditions associated with propulsion applications.

FEATURES:

- Lightweight, compact size <55 grams
- Flight heritage
- High accuracy, $\pm 0.3\%$ FSO RSS
- "S" Class electronics available
- Full traceability

APPLICATIONS:

- Miniature propulsion platforms
- Space vehicles
- Satellite propulsion
- Launch vehicles
- Life support systems

OPTIONS:

- mV/V, 0 to 5 Vdc, 0 to 10 Vdc (4-wire isolated output options) or 4-20 mA output
- Temperature (RTD) output
- Improved temperature compensation
- B+ and "S" Class electronics
- D38999/27YB98PN, D38999/27YA35PN electrical connectors
- Various MIL-SPECS available. Consult factory.

GP:50 MODEL 7900

REFERENCE SPECIFICATIONS

(Standard configurations shown, consult factory for other options)

ELECTRICAL	
Output Signal:	3mV/V, 0 to 5 Vdc and 0 to 10 Vdc isolated and non-isolated
Temperature Output:	100 Ohm 2 wire Platinum RTD 0.00385 Alpha $\Omega/\Omega/\text{deg C}$, Class B 1000 Ohm 2 wire Platinum RTD 0.00385 Alpha $\Omega/\Omega/\text{deg C}$, Class B
Excitation Voltage:	mv/v, 3.5 Vdc -15 Vdc 0-5 Vdc (3 wire, 4 wire non-isolated) 9-32 Vdc 0-10 Vdc and 0-5 Vdc isolated 14 to 32 Vdc
Circuit Protection:	EMI/RFI Reverse polarity protection (some options may affect rating)
Response Time:	<4 ms

MATERIALS OF CONSTRUCTION	
Wetted Parts:	17-4 PH or 316L pressure range dependent (Inconel, Hastelloy and Monel available)
Housing:	316L Stainless Steel

ACCURACY (RSS): Hysteresis, Non-Linearity & Repeatability @ +70 °F	
Static Accuracy (RSS):	$\leq \pm 0.3\%$ FSO
Non-linearity:	$\leq \pm 0.2\%$ FSO (Typ)
Hysteresis:	$\leq \pm 0.1\%$ FSO (Typ)
Repeatability:	$\leq \pm 0.1\%$ FSO (Typ)
Zero Balance:	$\pm 1.0\%$ FSO
Span Balance:	$\pm 1.0\%$ FSO

(BFSL method used. Improved options available.)

Calibration:	NIST Traceable Cert
Workmanship:	IPC-A-610 Soldering
Quality System:	ISO 9001

Options may affect specifications.
Please consult factory for your specific needs.

MECHANICAL	
Process Connection:	Welded 1/4" ID stainless steel tube, flow through, in-line design (other ports available)
Electrical Connection:	MIL-PTIH-10-6P standard, options available
Proof Pressure:	1.5X FSO
Burst Pressure:	2.0X FSO
Approximate Weight:	<2 oz (55 grams)

PRESSURE RANGES	
0 to 50 thru 0 to 5,000 PSIA, PSIG or PSISG (3.4 thru 345 BAR)	

THERMAL SPECIFICATIONS	
Operating Range:	-65 °F to +250 °F (-54 °C to +121 °C)
Compensated Range:	0 °F to +180 °F (-17.8 °C to +82 °C)
Compensated Ranges from -65 °F to +250 °F (-54 °C to +121 °C) available	
Thermal Error:	$\pm 1.0\%$ FSO/100 °F (Improved specifications available)

