

## MODEL 7720 CRYOGENIC PRESSURE TRANSDUCER

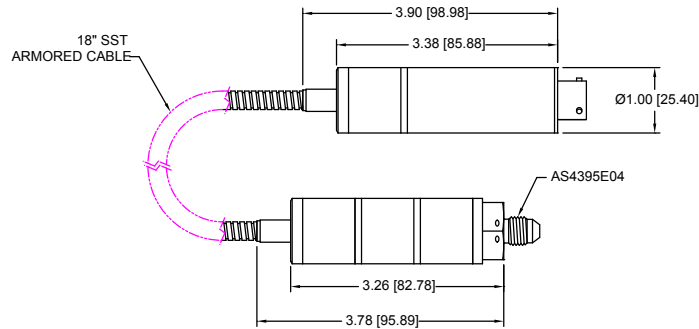

STANDARD WIRING

PIN	VDC	4-20mA
A/1	+EXC	+EXC/SIG
B/2	+SIG	N/C
C/3	-SIG	N/C
D/4	-EXC	-EXC/SIG
E/5	SHUNT (OPT.)	SHUNT (OPT.)
F/6	SHUNT (OPT.)	SHUNT (OPT.)

**REF DIMENSIONS ONLY.  
CONSULT FACTORY FOR ACTUAL DIMENSIONS.**

### PRODUCT OVERVIEW:

The Model 7720 Series from GP:50 is a family of cryogenic pressure transducers, offering consistent measurement accuracy in temperatures as low as -320 °F (-196 °C). The Series features a lightweight, all stainless steel construction with choice of either 4-20 mA, 0 to 5 Vdc, or 0 to 10 Vdc output; or optional digital protocols. On-board isolated transducer electronics are remotely mounted via stainless steel armor jacketed flex tubing. The high-reliability of the Model 7720 Series has been successfully field-proven over 25 years and hundreds of critical applications.

### FEATURES:

- Reliable cryogenic performance to -320 °F (-196 °C)
- Hydrogen and LOX compatible options available
- Isolated remote electronics via stainless steel armored flex tubing
- Standard accuracy to +0.3% FSO
- Lightweight, all stainless steel construction (<10 oz.; 0.2 kg)
- Choice of 4-20 mA, 0-5 Vdc, 0-10 Vdc or optional digital output

### APPLICATIONS:

- LNG pressures
- Aerospace propulsion systems
- Military and defense programs
- Liquid gas custody transfer

### OPTIONS:

- 0 to 5 Vdc, 0 to 10 Vdc or 4-20 mA output
- RS232, RS485 and CAN outputs
- Zero and span adjustments
- Optional electrical connections
- High-temperature version to +350 °F (+177 °C) (see Model 7780)
- Various MIL-SPECS available. Consult factory.

# GP:50 MODEL 7720

## REFERENCE SPECIFICATIONS

(Standard configurations shown, consult factory for other options)

ELECTRICAL	
Output Signal:	0 to 5 Vdc, 0 to 10 Vdc (3- and 4-wire isolated or non-isolated) and 4-20 mA
Excitation Voltage:	18 to 36 Vdc, 9 to 36 Vdc (unregulated)
Circuit Protection:	EMI/RFI, some options will affect EMI/RFI rating
Response Time:	4 ms

MATERIALS OF CONSTRUCTION	
Wetted Parts:	17-4-PH SST (Inconel, Nitronic 50 or Monel available)
Housing:	316L Stainless Steel
Armored Cable:	316L

ACCURACY (BFSL): Hysteresis, Non-Linearity & Repeatability @ +70 °F	
Static Accuracy (RSS):	$\leq \pm 0.3\%$ FSO
Non-linearity:	$\leq \pm 0.20\%$ FSO (Typ)
Hysteresis:	$\leq \pm 0.1\%$ FSO (Typ)
Repeatability:	$\leq \pm 0.1\%$ FSO (Typ)
Zero Balance:	$\pm 1.0\%$ FSO
Span Balance:	$\pm 1.0\%$ FSO

(BFSL method used. Improved options available.)

Calibration:	NIST Traceable Cert
Workmanship:	IPC-A-610 Soldering
Quality System:	ISO 9001

Options may affect specifications.  
Please consult factory for your specific needs.

MECHANICAL	
Process Connection:	AS4395E04 pressure port
Electrical Connection:	MIL PTIH-10-6P standard, options available
Proof Pressure:	1.5X range
Burst Pressure:	2X range
Approximate Weight:	<10 oz. (0.2 kg)

PRESSURE RANGES	
Standard Ranges:	0 to 300 thru 0 to 6K PSI (20 thru 413 BAR)
Consult factory for ranges <300 PSI or >6,000 PSI	

THERMAL SPECIFICATIONS	
Operating Range:	Ambient: -40°F to +185°F (-40 °C to +85 °C) Process: -320 °F to +185 °F (-196 °C to +85 °C)
Compensated Range:	-320 °F to +70 °F (-196 °C to +21.1 °C)
Effect on Zero & Span:	$\pm 1.0\%$ FSO/100 °F (Improved specifications available)

