

MODEL 7300 FLIGHT HERITAGE DIFFERENTIAL PRESSURE TRANSDUCER



STANDARD WIRING

PIN	4-20mA	4-WIRE VDC ISOLATED	4-WIRE VDC NON-ISOLATED	3-WIRE VDC
1/RED	+EXC/SIG	+EXC	+EXC	+EXC
2/GRN	N/C	+SIG	+SIG	+SIG
3/WHT	N/C	-SIG	-SIG*	N/C
4/BLK	-EXC/SIG	-EXC	-EXC*	-EXC/SIG
5/BLU	N/C	N/C	N/C	N/C
6/BRN	N/C	N/C	N/C	N/C

* COMMONS JUMPERED

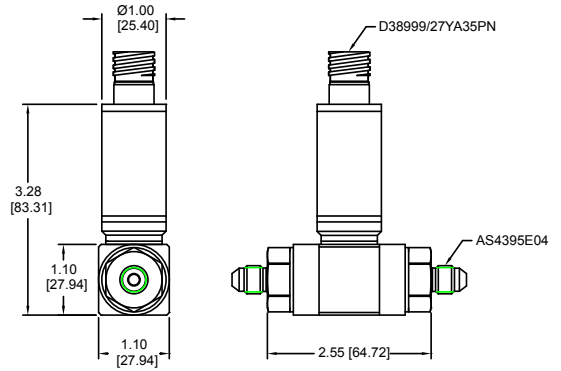

**REF DIMENSIONS ONLY.
CONSULT FACTORY FOR ACTUAL DIMENSIONS.**

PRODUCT OVERVIEW:

GP:50 Model 7300 is a flight heritage, differential pressure transducer digitally corrected to provide high-accuracy pressure measurement. The compact, proprietary sensor design provides added zero stability required for commercial aviation, military, aerospace, UAV, satellite, and defense applications.

FEATURES:

- Accuracy to 0.1% FSO
- Extremely lightweight, <8 oz (0.2 kg)
- 0 to 5 Vdc, 0 to 10 Vdc, or 4-20mA output
- Line pressure shift <1% FSO/100 PSI
- 1000 PSI line pressure rating
- Ranges from 0-1 thru 0-500 PSID

APPLICATIONS:

- Aviation and suborbital spacecraft
- Space heritage flight
- Commercial and military satellites
- Launch vehicles
- Test stand applications
- Ground and engine testing

OPTIONS:

- Digital correction provides an optional 0.05% FSO accuracy
- 0 to 5 Vdc, 0 to 10 Vdc isolated output
- Bi-directional operation
- Fomblin Oil fill for O₂ applications
- Various MIL-SPECS available. Consult factory.

GP:50 MODEL 7300

REFERENCE SPECIFICATIONS

(Standard configurations shown, consult factory for other options)

ELECTRICAL	
Output Signal:	4-20mA, 0 to 5 Vdc or 0 to 10 Vdc
Excitation Voltage:	8 to 32 Vdc (4-20mA, and 0-5 Vdc non-isolated output) 12-32 Vdc (0-10 Vdc and 0-5 Vdc isolated output)
RLoad max:	$(4-20 \text{ mA}) = ((\text{Power supply Voltage} - 9.0\text{V}) / .020) - \text{Wire Resistance}$. (Options may affect this, consult factory)
Circuit Protection:	EMI/RFI, Reverse Polarity
Response Time:	~1 ms

MATERIALS OF CONSTRUCTION	
Wetted Parts:	316L Stainless Steel
Housing:	300 Series Stainless Steel
O-Ring:	Buna-N (Nitrile) is standard. For expanded temp ranges (-65 °F to 350 °F, 54 °C to 177 °C) Fluorosilicone is standard.
Internal Fill:	Silicone Oil (Fomblin oil available)

ACCURACY (RSS): Hysteresis, Non-Linearity & Repeatability @ +70 °F	
Static Accuracy (RSS):	≤ ±0.3% FSO
Non-Linearity:	≤ ±0.2% FSO (Typ)
Hysteresis:	≤ ±0.1% FSO (Typ)
Repeatability:	≤ ±0.1% FSO (Typ)
Zero Balance:	± 1.0% FSO
Span Balance:	± 1.0% FSO

(BFSL method used. Improved options available.)

Calibration:	NIST Traceable Cert
Workmanship:	IPC-A-610 Soldering
Quality System:	ISO 9001

Options may affect specifications.
Please consult factory for your specific needs.

MECHANICAL	
Process Connection:	AS4395E04 standard (Optional pressure ports available)
Electrical Connection:	D38999 standard, options available
Proof Pressure:	3X pressure range (Higher available)
Burst Pressure:	5X pressure range
Static Pressure:	1000 PSI
Random Vibration:	>25 G RMS (20 Hz to 2,000 Hz)
Orientation Effect ≤2 PSI:	±3.5% FSO, Rotated 90° from Horizontal
Approximate Weight:	<8 oz (0.2 kg) (Some options may affect weight)

PRESSURE RANGES	
0 to 1 thru 0 to 500 PSID (0.07 BAR thru 34.5 BAR) (Bidirectional or unidirectional)	

THERMAL SPECIFICATIONS	
Operating Range:	-40 °F to +250 °F (-40 °C to +121 °C)
Compensated Range:	0 °F to +180 °F (-18 °C to +82 °C) (Other available)
Compensated Ranges from -65 °F to +250 °F (-54 °C to +121 °C)	
Effect on Zero & Span:	± 1.0% FSO/100 °F (Improved specifications available)

